

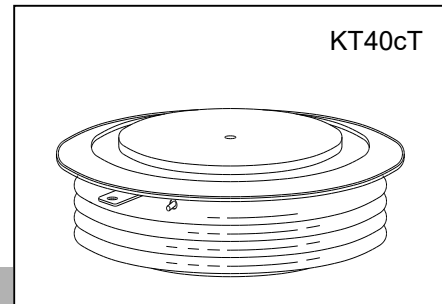

HIGH POWER THYRISTOR FOR PHASE CONTROL APPLICATIONS

Features:

- . All Diffused Structure
- . Interdigitated Amplifying Gate Configuration
- . Blocking capability up to 4500 volts
- . Guaranteed Maximum Turn-Off Time
- . High dV/dt Capability
- . Pressure Assembled Device



ELECTRICAL CHARACTERISTICS AND RATINGS

Blocking - Off State

Device Type	V _{RRM} (1)	V _{DRM} (1)	V _{RSM} (1)
YC604CN	3800	3800	3900
YC604DP	4000	4000	4100
YC604DB	4200	4200	4300
YC604DD	4400	4400	4500
YC604DE	4500	4500	4600

V_{RRM} = Repetitive peak reverse voltage
 V_{DRM} = Repetitive peak off state voltage
 V_{RSM} = Non repetitive peak reverse voltage (2)

Repetitive peak reverse leakage and off state leakage	I _{RRM} / I _{DRM}	15 mA 35 mA (3)
Critical rate of voltage rise	dV/dt (4)	200 V/μsec

Notes:

- All ratings are specified for T_j=25 °C unless otherwise stated.
- (1) All voltage ratings are specified for an applied 50Hz/60zHz sinusoidal waveform over the temperature range -40 to +125 °C.
 - (2) 10 msec. max. pulse width
 - (3) Maximum value for T_j = 125 °C.
 - (4) Minimum value for linear and exponential waveshape to 80% rated V_{DRM}. Gate open. T_j = 125 °C.
 - (5) Non-repetitive value.
 - (6) The value of di/dt is established in accordance with EIA/NIMA Standard RS-397, Section 5-2-2-6. The value defined would be in addition to that obtained from a snubber circuit, comprising a 0.2 μF capacitor and 20 ohms resistance in parallel with the thristor under test.

Conducting - on state

Parameter	Symbol	Min.	Max.	Typ.	Units	Conditions
Average value of on-state current	I _{T(AV)}		400		A	Sinewave, 180° conduction, T _c =65°C
RMS value of on-state current	I _{TRMS}		628		A	Nominal value
Peak one cycle surge (non repetitive) current	I _{TSM}		4500		A	8.3 msec (60Hz), sinusoidal wave-shape, 180° conduction, T _j = 125 °C
			5100		A	10.0 msec (50Hz), sinusoidal wave-shape, 180° conduction, T _j = 125 °C
I square t	I ² t		130000		A ² s	8.3 msec
Latching current	I _L		800		mA	V _D = 24 V; R _L = 12 ohms
Holding current	I _H		400		mA	V _D = 24 V; I = 2.5 A
Peak on-state voltage	V _{TM}		2.1		V	I _{TM} = 500 A;
Critical rate of rise of on-state current (5, 6)	di/dt		400		A/μs	Switching from V _{DRM} ≤ 1000 V, non-repetitive
Critical rate of rise of on-state current (6)	di/dt		150		A/μs	Switching from V _{DRM} ≤ 1000 V

Gating

Parameter	Symbol	Min.	Max.	Typ.	Units	Conditions
Peak gate power dissipation	P_{GM}		200		W	$t_p = 40 \mu s$
Average gate power dissipation	$P_{G(AV)}$		5		W	
Peak gate current	I_{GM}		10		A	
Gate current required to trigger all units	I_{GT}		300 200 125		mA mA mA	$V_D = 6 V; R_L = 3 \text{ ohms}; T_j = -40 \text{ }^\circ\text{C}$ $V_D = 6 V; R_L = 3 \text{ ohms}; T_j = +25 \text{ }^\circ\text{C}$ $V_D = 6 V; R_L = 3 \text{ ohms}; T_j = +125 \text{ }^\circ\text{C}$
Gate voltage required to trigger all units	V_{GT}	0.30	5 3		V V V	$V_D = 6 V; R_L = 3 \text{ ohms}; T_j = -40 \text{ }^\circ\text{C}$ $V_D = 6 V; R_L = 3 \text{ ohms}; T_j = 0-125 \text{ }^\circ\text{C}$ $V_D = \text{Rated } V_{DRM}; R_L = 1000 \text{ ohms}; T_j = +125 \text{ }^\circ\text{C}$
Peak negative voltage	V_{GRM}		5		V	

Dynamic

Parameter	Symbol	Min.	Max.	Typ.	Units	Conditions
Delay time	t_d		1.5	0.7	μs	$I_{TM} = 50 \text{ A}; V_D = 67\% V_{DRM}$ Gate pulse: $V_G = 30 \text{ V}; R_G = 10 \text{ ohms}; t_r = 0.1 \mu s; t_p = 20 \mu s$
Turn-off time (with $V_R = -5 \text{ V}$)	t_q		250	125	μs	$I_{TM} > 1000 \text{ A}; di/dt = 25 \text{ A}/\mu s;$ $V_R \geq -5 \text{ V};$ Re-applied $dV/dt = 200 \text{ V}/\mu s$ linear to $67\% V_{DRM}$; $T_j = 125 \text{ }^\circ\text{C};$ Duty cycle $\geq 0.01\%$
Reverse recovery charge	I_{rr}				μC	$I_{TM} > 1000 \text{ A}; di/dt = 25 \text{ A}/\mu s;$ $V_R \geq -50 \text{ V}; T_j = 125 \text{ }^\circ\text{C}$

THERMAL AND MECHANICAL CHARACTERISTICS AND RATINGS

Parameter	Symbol	Min.	Max.	Typ.	Units	Conditions
Operating temperature	T_j	-40	+125		$^\circ\text{C}$	
Storage temperature	T_{stg}	-40	+150		$^\circ\text{C}$	
Thermal resistance - junction to case	$R_{\Theta(j-c)}$		0.040 0.080		$^\circ\text{C}/\text{W}$	Double sided cooled Single sided cooled
Thermal resistance - case to sink	$R_{\Theta(c-s)}$		0.008 0.016		$^\circ\text{C}/\text{W}$	Double sided cooled * Single sided cooled
Mounting force	P	3000 13.4	3500 15.7	15	lb. kN	
Weight	W			9 260	oz g.	

* Mounting surfaces smooth, flat and greased

