



### GENERAL PURPOSE THYRISTOR MODULE

#### Features:

- . Electrical insulation between chip and base plate, 2500V AC insulation
- . Compact structure
- . Excellent temperature characteristics and power cycling capability
- . Small size & light weight

#### Typical application:

- . AC / DC motor control
- . Various rectification power supplies
- . Frequency converter



### ELECTRICAL CHARACTERISTICS AND RATINGS

Symbol	Parameter	Conditions	Tj(°C)	Value			Unit
				Min	Typ	Max	
I <sub>T(AV)</sub>	Mean on-state current	Sinewave 180°,50Hz Single side cooling, T <sub>c</sub> =85°C	125			135	A
I <sub>T(RMS)</sub>	RMS on-state current		125			212	A
V <sub>DRM</sub> V <sub>RRM</sub>	Repetitive peak off-state voltage Repetitive peak reverse voltage	V <sub>DRM</sub> &V <sub>RRM</sub> tp=10ms V <sub>DSM</sub> &V <sub>RSM</sub> =V <sub>DRM</sub> &V <sub>RRM</sub> +200V	25	1200		2000	V
I <sub>DRM</sub>	Repetitive peak off-state current	V <sub>DM</sub> = V <sub>DRM</sub>	125			15	mA
I <sub>RRM</sub>	Repetitive peak reverse current	V <sub>RM</sub> = V <sub>RRM</sub>					
I <sub>TSM</sub>	Surge on-state current	10ms bottom width, half sine wave	125			5.20	KA
I <sup>2</sup> t	I squared t	V <sub>R</sub> =0.6V <sub>RRM</sub>				135	A <sup>2</sup> s*10 <sup>3</sup>
V <sub>TO</sub>	On-state threshold voltage		125			0.8	V
r <sub>T</sub>	Slope resistance					1.85	mΩ
V <sub>TM</sub>	Peak on-state voltage	I <sub>TM</sub> =400A	25			1.45	V
dv/dt	Critical rise rate of off-state voltage	V <sub>DM</sub> =67%V <sub>DRM</sub>	125			1000	V/μs
di/dt	Critical rise rate of on-state current	I <sub>TM</sub> =270A Amplitude of gate trigger current I <sub>GM</sub> = 1.5A Gate current rise time t <sub>r</sub> ≤0.5 s	125			100	A/μs
I <sub>GT</sub>	Gate trigger current	V <sub>O</sub> =12V, R <sub>L</sub> =3Ω	25	30		100	mA
V <sub>GT</sub>	Gate trigger voltage			0.8		2.5	V
I <sub>H</sub>	Holding current			20		150	mA
I <sub>L</sub>	Latching Current					1000	mA
V <sub>GD</sub>	Gate non-trigger voltage	V <sub>DM</sub> =67%V <sub>DRM</sub>	125	0.2			V
R <sub>th(j-c)</sub>	Thermal impedance(junction to case)	180° sine wave, single side heat dissipation				0.200	°C /W
R <sub>th(c-h)</sub>	Thermal impedance(case to heatsink)	180° sine wave, single side heat dissipation				0.08	°C /W
V <sub>iso</sub>	Insulation voltage	50Hz,R.M.S,t=1min,I <sub>iso</sub> :1mA(MAX)		2500			V
F <sub>m</sub>	Electrode mounting torque (M6)					6	N·m
	Base plate mounting torque (M6)					6	N·m
T <sub>stg</sub>	Storage temperature			-40		125	°C
W <sub>t</sub>	Weight					320	g

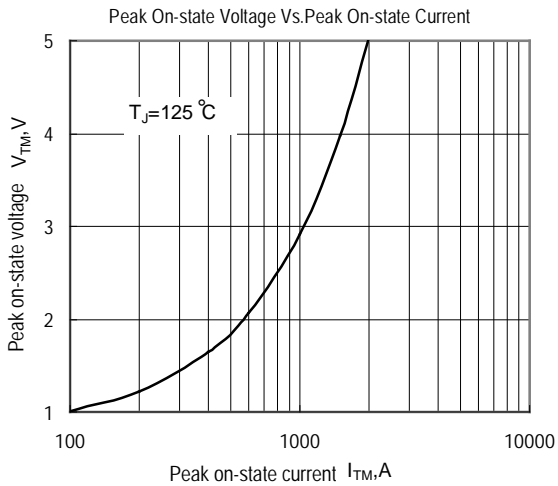

Fig.1 On-state Volt-ampere Characteristic

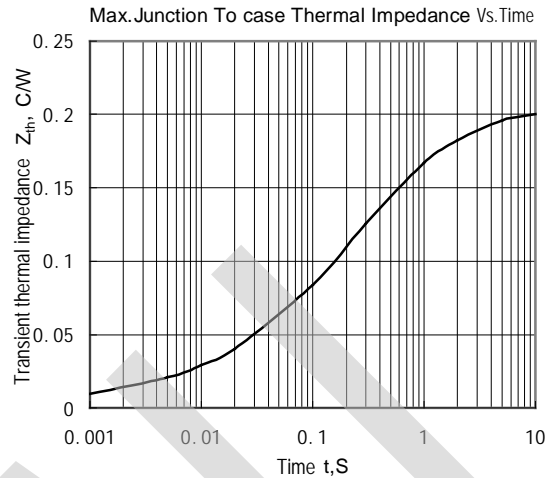

Fig.2 Transient Thermal Impedance of Junction to Case

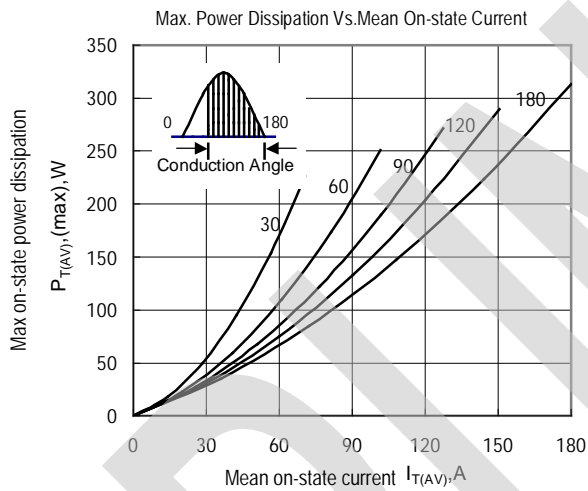

Fig.3 Max Power Dissipation Vs. Mean On-state Current

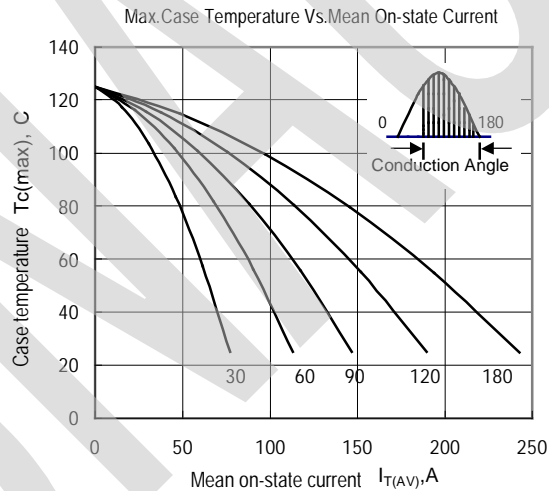

Fig.4 Max case Temperature Vs. Mean On-state Current

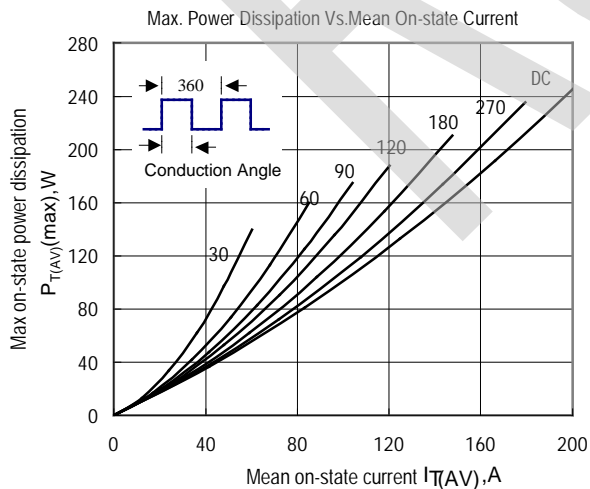

Fig.5 Max Power Dissipation Vs. Mean On-state Current

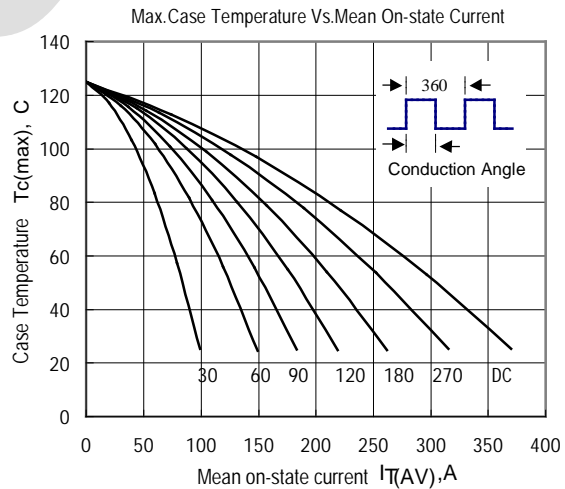

Fig.6 Max Case Temperature Vs. Mean On-state Current

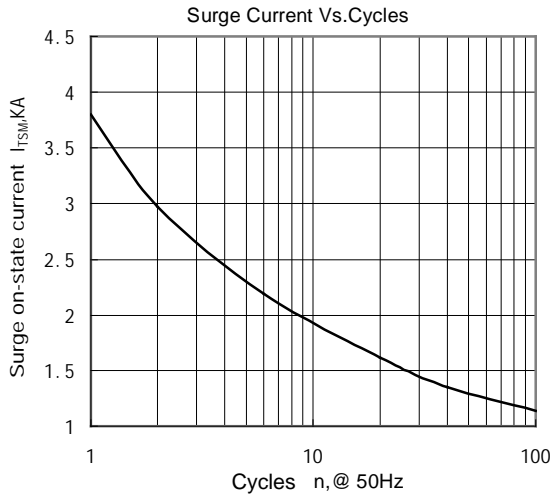

Fig.7 Surge Current Vs.Cycles

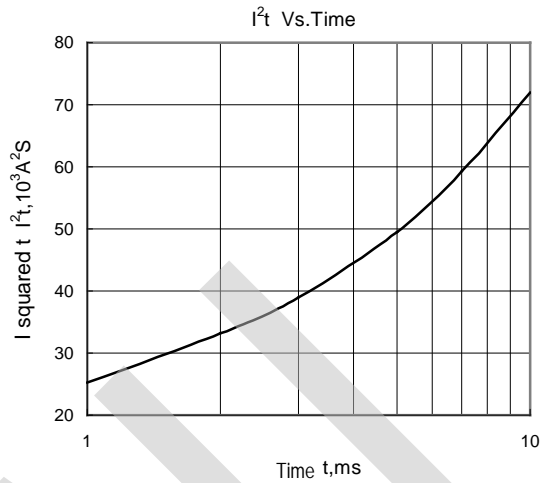

Fig.8 I<sup>2</sup>t Vs.Time

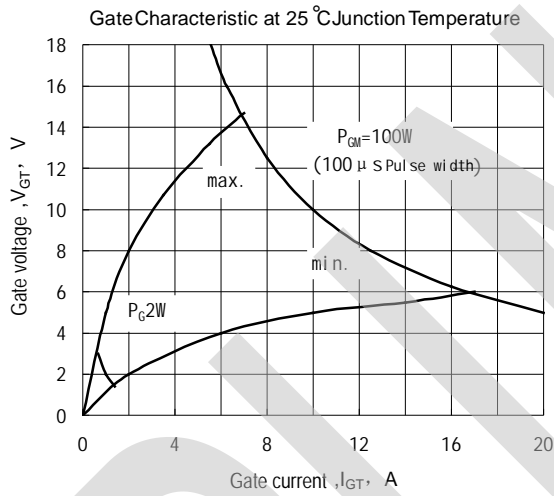

Fig.9 Gate Power Graph

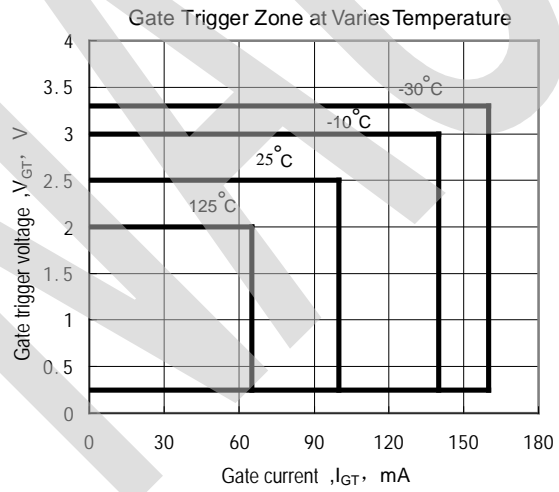
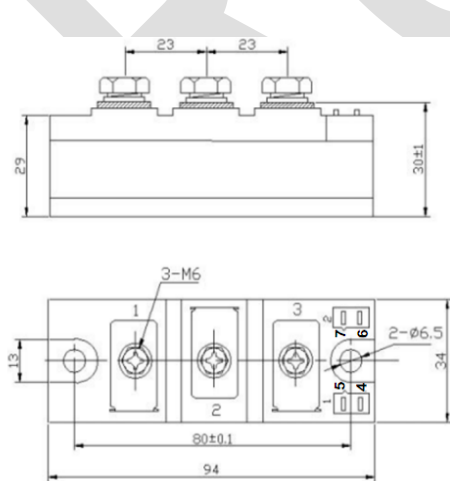

Fig.10 Gate Trigger Characteristic Graph

**OUTLINE**



**M234F**

