

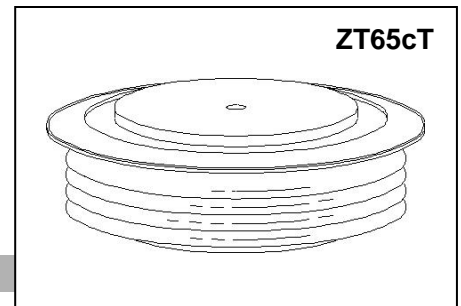

GENERAL PURPOSE HIGH POWER STANDARD RECTIFIER

Features:

- . All Diffused Structure
- . High Surge rating
- . Blocking capability up to 1600 volts
- . Ceramic Housing Hermetic Package
- . Pressure Assembled Device



ELECTRICAL CHARACTERISTICS AND RATINGS

Reverse Blocking

Device Type	V _{RRM} (1)	V _{RSM} (1)
ZP3200-06	600	800
ZP3200-08	800	1000
ZP3200-10	1000	1200
ZP3200-12	1200	1400
ZP3200-14	1400	1600
ZP3200-16	1600	1800

V_{RRM} = Repetitive peak reverse voltage

V_{RSM} = Non repetitive peak reverse voltage (2)

Repetitive peak reverse leakage	I _{RRM}	5 mA 70 mA (3)
---------------------------------	------------------	-------------------

Notes:

All ratings are specified for T_j=25 °C unless otherwise stated.

(1) All voltage ratings are specified for an applied 50Hz/60Hz sinusoidal waveform over the temperature range 0 to +175 °C.

(2) 10 msec. max. pulse width

(3) Maximum value for T_j = 175 °C.

(4) See parameter definition below:

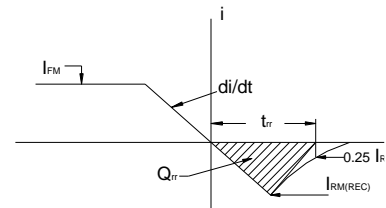

REVERSE RECOVERY CHARACTERIST

Conducting - on state

Parameter	Symbol	Min.	Max.	Typ.	Units	Conditions
Average forward current	I _{F(AV)}		3200		A	Sinewave, 180°, T _c =100 °C
RMS forward current	I _{FRMS}		5024		A	Nominal value
Peak one cycle surge (non repetitive) current	I _{FSM}		35200		A	10 msec (50Hz), sinusoidal wave-shape, 180° conduction, T _j = 175 °C
I square t	I ² t		6.2 × 10 ⁶		A ² s	10 msec
Peak forward voltage	V _{FM}		1.30		V	I _{FM} = 3000A;T _j =25°C
Threshold voltage	V _{FO}		0.78		V	T _j =175°C,I=0.5 π I _{F(AV)} to 1.5 π I _{F(AV)}
Slope resistance	r _F		0.075		mΩ	T _j =175°C,I=0.5 π I _{F(AV)} to 1.5 π I _{F(AV)}
Reverse Recovery Current (4)	I _{RM(REC)}				A	I _{FM} = 500 A; di/dt = -10 A/s;T _j max
Reverse Recovery Charge (4)	Q _{rr}			4000	μC	I _{FM} = 500 A; di/dt = -10 A/s;T _j max
Reverse Recovery Time (4)	t _{rr}				μs	I _{FM} = 500 A; di/dt = -10 A/s;T _j max

Parameter	Symbol	Min.	Max.	Typ.	Units	Conditions
Operating temperature	T_j	-40	+175		°C	
Storage temperature	T_{stg}	-40	+175		°C	
Thermal resistance - junction to case	$R_{\Theta(j-c)}$		0.015		°C/W	Double sided cooled
Thermal resistance - case to heatsink	$R_{\Theta(c-s)}$		0.005		°C/W	Double sided cooled
Mounting force	P	27	33	30	kN	
Weight	W			0.72	kg.	

* Mounting surfaces smooth, flat and greaseless

CASE OUTLINE AND DIMENSIONS

